



ALPINE

RESORT

2026 WEDDINGS



ALPINE

RESORT

The Alpine Resort...

*D*iscovered and developed in 1921, the Alpine Resort was built by brothers Paul and John Bertschinger. At first sight, the duo fell in love the property's natural beauty and resort potential, initially selling it, then repurchasing it after much remorse. The Bertschinger brothers envisioned the perfect weekend getaway, and the Alpine Resort was born, opening its doors to guests in 1922.



Waterfront Tent



DAY OF EVENT INCLUSIONS:

- Exclusive use of the 4000 sq ft sail cloth tent
- Full clear side panels for the tent if needed
- Italian Lighting on dimmers
- Full wood flooring throughout the tent



Facility Inclusions



- Round 66" tables for guests seating (up to 10 per table) Maximum seating for 200
- Additional accent tables available in various sizes and heights
- Glassware for cocktail hour and dinner, plastic provided after dinner service
- Full place setting for dinner
- Bathroom facilities adjacent to the tent
- Detailed full layouts for tent space
- Cross back wood chairs available
- White, garden style folding chairs

The Details



- All decorations must be freestanding. Decorations may not be hung from light fixtures, nor attached to the tent or Alpine Resort buildings
- Rice, confetti, birdseed, flower petals, balloons, glitter, fog machines, pyrotechnics, sparklers, fireworks, and bubble machines are not permitted inside or outside of the facilities
- LED candles are permitted inside and outside. No open flame candles are permitted.



- All decorations must be pre-approved by the Alpine Resort
- Smoking is only permitted in designated areas
- All desserts other than wedding cake will be provided by Alpine
- Heaters in tent available for an additional fee
- All property belonging to the client, guests and vendors shall be delivered and removed the day of the contracted event
- All amplified music and live bands must cease at 11:00pm due to local ordinances



The Details



- Clients and guests must be out of the tent no later than 11:15pm
- Additional fees will apply for all guests staying past the end time
- All vendors must be out by 11:59pm
- Client expressly grants Alpine Resort permission to take photographs of the event and use them for marketing purposes
- Any guest room delivery must be communicated 2 weeks prior to event date. There is a \$2.00 per room charge for all gift bag deliveries. All bags must be the same for each cabin
- Pricing for 2026 Waterfront Tent is \$18,000 with a food and beverage minimum of \$20,000
- 22% service charge is added
- The total bill which includes food, beverage, service charge, room rental and any additional charges are subject to a WI and local tax of 5.5%
- Initial payment: In order to lock in a date, a contract will be provided to the client which needs to be signed and returned with the retainer, which is the cost of the venue rental fee

Financials



After a date is contracted,
the below will take place:

1. All available cabins will be blocked for your group. A deposit of 50% will be due with each guest's booking.
2. Your Alpine representative will reach out to get a tasting date in place

You can bring up to a maximum of 6 total people to your tasting

3 salads, 3 entrees, along with 5 sides (veggie and starch)

3. Three months prior to the event date, your preliminary food (for dinner, you will be allowed to choose 3 total entrees including a vegetarian meal) and beverage decisions are due to Alpine along with a 50% payment that will be applied to the estimated Banquet Event Order.
4. Twenty-one days prior to your event date, the balance is required based on your Banquet Event Order.

A credit card will be placed on file for any outstanding charges or incidentals to be collected after full payment

All payments are due by check or wire transfer

Lodging Information



- During your stay, you'll have access to complimentary wifi, self-service laundry facility, golf and on site bar and restaurant.
- Each charming 1 to 3 bedroom cottage is newly modernized with updated cozy features – including fully renovated baths, climate control, service bar, plus a porch with cedar plank floors. Select cottages include dual porches and waterfront views.
- Room blocks will not be set up until contract and retainer is received. They will be based on estimated guest count and availability. Deposits on all guest rooms must be paid 6 months prior to the event. The guest room block, and rate will be guaranteed until this date. Once the date has passed, unreserved rooms still within your block will be released. Alpine Resort does not guarantee your group rate after the cut-off date.



Relaxing Accommodations

1 BEDROOM/1 BATH (Nightly Rate)

Alabama	383 Sq Ft	\$350
Idaho	383 Sq Ft	\$350
Iowa	404 Sq Ft	\$350
Kansas	383 Sq Ft	\$350
Michigan	383 Sq Ft	\$350
Minnesota	383 Sq Ft	\$350
Mississippi	383 Sq Ft	\$350
Nevada	383 Sq Ft	\$350
Ohio	380 Sq Ft	\$350
Oklahoma	383 Sq Ft	\$350
Virginia	383 Sq Ft	\$350



2 BEDROOM/1 BATH (Nightly Rate)

Arizona	510 Sq Ft	\$400
Florida	510 Sq Ft	\$400
Indiana	551 Sq Ft	\$400
Maine	510 Sq Ft	\$400
Missouri	551 Sq Ft	\$400
New York	661 Sq Ft	\$400
Tennessee	510 Sq Ft	\$400

2 BEDROOM/2 BATH (Nightly Rate)

Arkansas	661 Sq Ft	\$400
Kentucky	661 Sq Ft	\$400
Maryland	900 Sq Ft	\$400
Louisiana	900 Sq Ft	\$400

CLUBHOUSE ROOMS

1 BEDROOM/1 BATH (Nightly Rate)

Suite 1	236 Sq Ft	\$340
Suite 2	157 Sq Ft	\$340
Suite 3	254 Sq Ft	\$340
Suite 4	241 Sq Ft	\$340
Suite 5	282 Sq Ft	\$340

3 BEDROOM/1 BATH (Nightly Rate)

California	596 Sq Ft	\$460
Illinois	596 Sq Ft	\$460
Nebraska	596 Sq Ft	\$460
Oregon	641 Sq Ft	\$460
Pennsylvania	510 Sq Ft	\$460
Texas	641 Sq Ft	\$460
Wisconsin	596 Sq Ft	\$460



Subject to availability. Prices accurate as of October, 2024

www.alpineresort.com
 920.868.3000
 7715 Alpine Road
 Egg Harbor, WI 54209

ALPINE RESORT



Alpine Lane

First Lane

Alpine Road

MAIN ENTRANCE

Horseshoe Bay Road

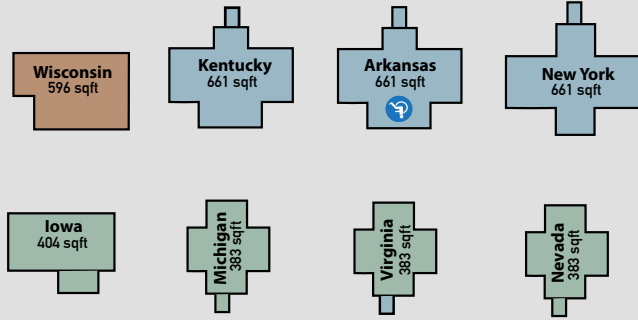

Second Lane

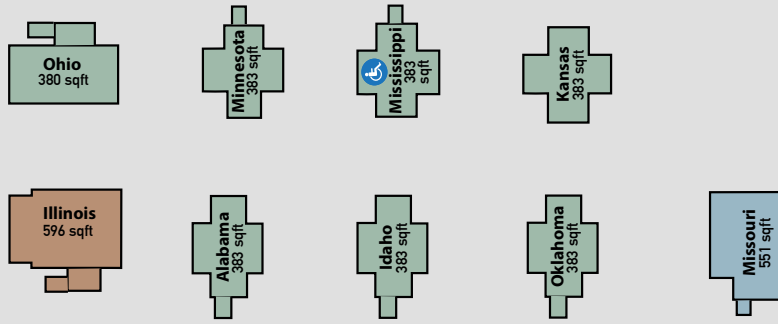

Third Lane

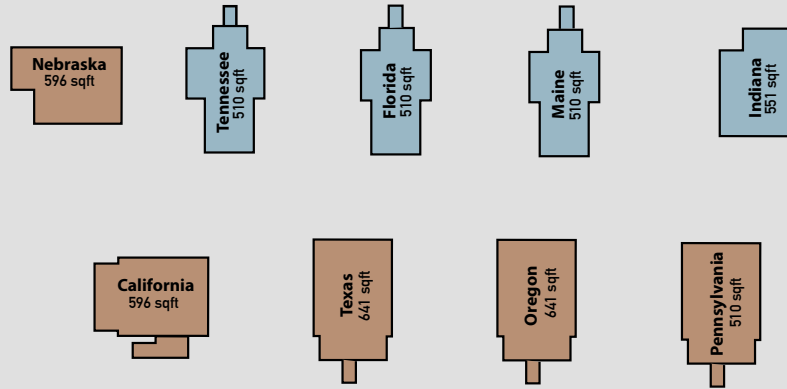

Fourth Lane

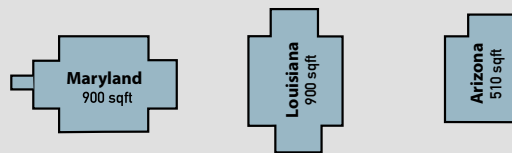

- 1 Bedroom
- 2 Bedroom
- 3 Bedroom

GOLF COURSE CLUB ROOMS
 ← 5 Suites with King Beds